

P55D

REDEFINING THE MILLING ERA

Breaking Free from Compressed Air Dependency

5

Axes

1

Disc

6

Blocks

13

Tools

59dB

Quiet Milling

Small
Footprint

Easy
Using



P55D

INNOVATIVE DIGITAL MILLING MACHINE, UNLOCKING ENDLESS POSSIBILITIES!

Designed for both dental laboratories and clinics, the P55D effortlessly meets the demands for efficient milling and precise aesthetics. It optimizes workflows to achieve the most satisfactory result in restoration milling, boasting a remarkable 3 μm repeat accuracy that ensures exceptional precision in every operation.

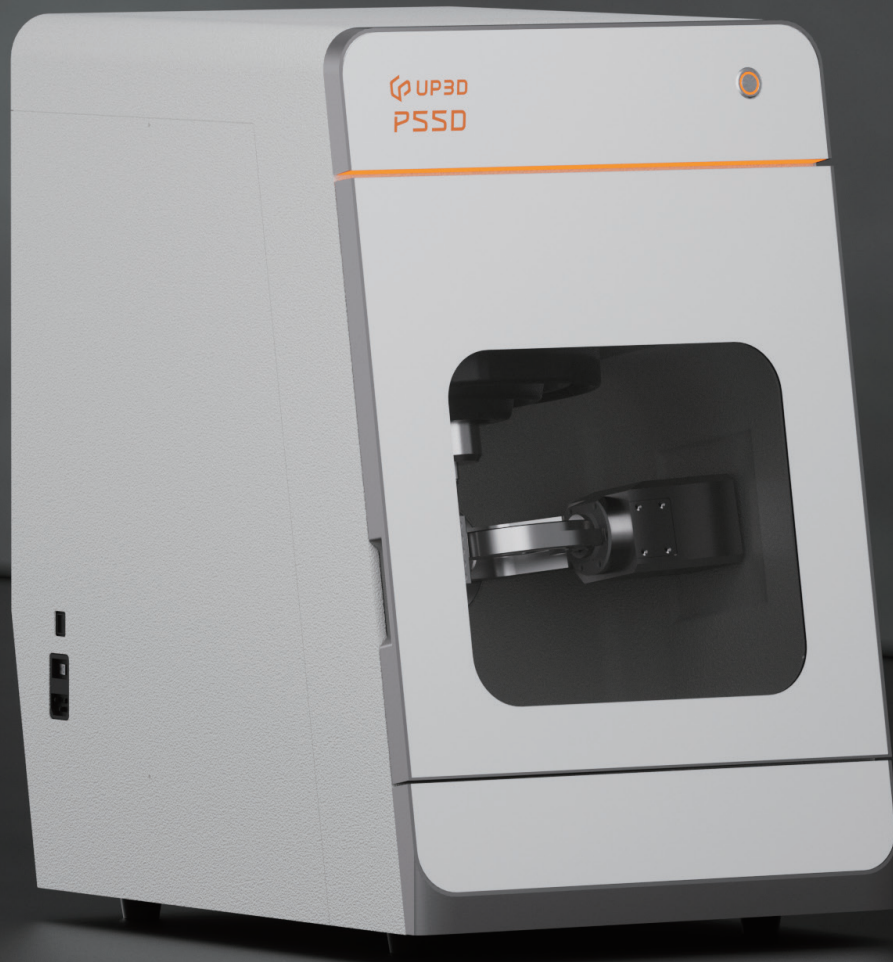

P55D

ACHIEVE UNRESTRICTED MILLING, HIGH-QUALITY RESTORATIONS MADE EASY!

No need air compressor save your cost and make the installation easy. Integrated UPCAM software effortlessly introduces you to the world of dental restorations.

Begin your milling journey with effortless Plug-and-Play set-up!
Say goodbye to clumsy noisy compressor.



BRAND NEW P55D
A DECADE OF INNOVATION
LEADING TECHNOLOGY
NO NEED FOR COMPRESSED AIR



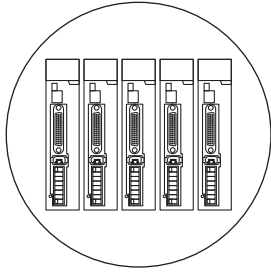

THE SMART SERVO DRIVE

STABLE MILLING WITH PRECISION DOWN TO THE MICRON

The full servo drive system precisely compensates for minor vibrations during the milling process, ensuring stable, efficient, and continuous production around the clock. It achieves precision machining, perfectly handling even the most complex restoration.

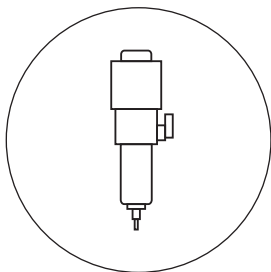

HIGH-QUALITY SPINDLE

GERMAN ENGINEERING. STRONGER AND AIR-FREE

Featuring a German 60,000rpm high-power electric spindle, P55D offers reliable performance for milling complex cases and hard materials. Its compressed air-free design streamlines operations—Simply plug and mill.

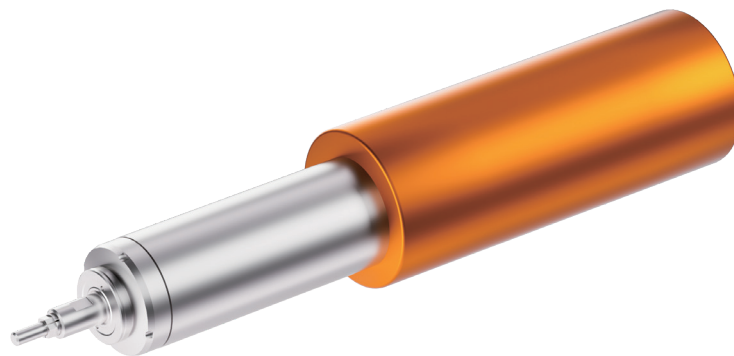



SMART REMOTE CONTROL

MILL MANAGE AT YOUR FINGERTIP

Utilize MillMind app for smart remote control, coupled with smart milling alerts and tool life monitoring. This reduces downtime and significantly enhances efficiency, making the workflow more effective.

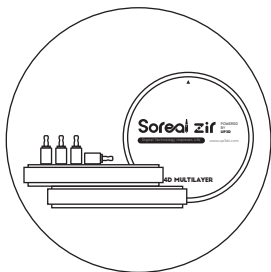

MATERIAL FLEXIBILITY

EFFICIENCY ENHANCEMENT THROUGH CUSTOM SOLUTIONS

Supports a variety of popular materials such as zirconia, wax, PMMA, PEEK, composite resin and soft metals. Compatible with both disc and block formats, it offers custom-tailored, efficient restoration solutions to meet the needs of diverse cases.

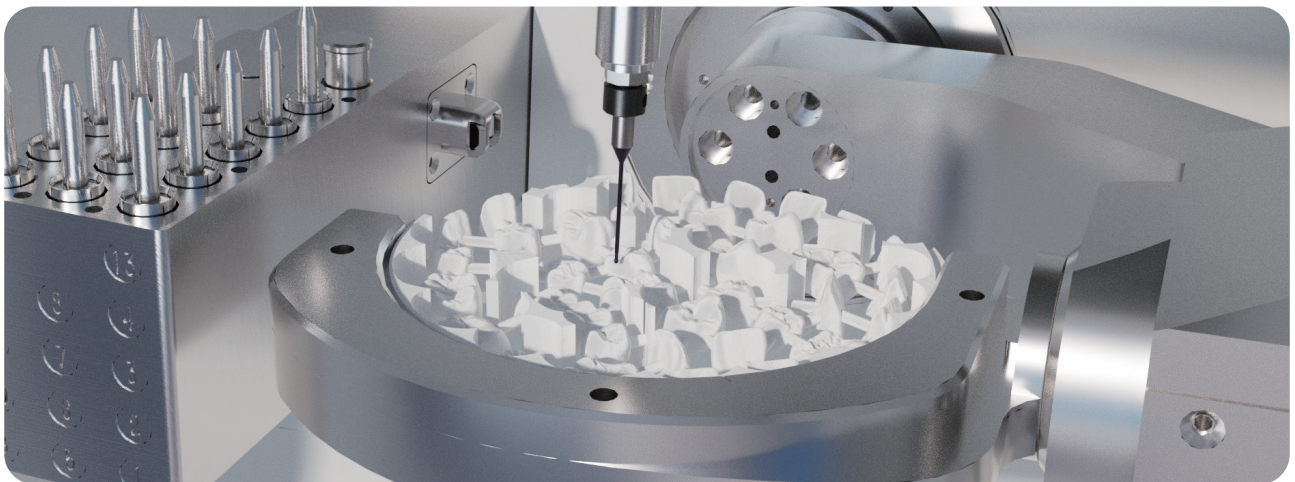



FREEDOM OF CHOICE IN CREATION



MATERIALS	 Zirconia	 PMMA	 PEEK	 Composite Resin
 Coping/ Full Crown	✓	✓	✓	✓
 Three-Unit Bridge	✓	✓	✓	✓
 Inlay/Onlay	✓			✓
 Veneers	✓			✓
 Screw-Retained Crown	✓	✓		✓
 Custom Abutment	✓		✓	
 Thimble Bar	✓		✓	
 Partial Denture Frameworks	✓	✓	✓	
 Superstructures Over Bars	✓	✓		
 Full Dentures		✓		
 Full Dentures without Teeth		✓		
 Bite Splint		✓		

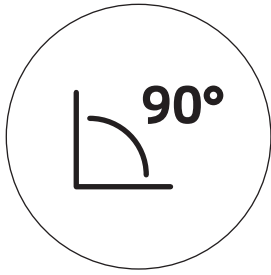

90° MILLING

RECREATING AESTHETIC DETAILS

Perfectly recreate the detailed contours of teeth with 90-degree vertical milling. This method precisely machines textures on the labial (or buccal) sides, reducing handmade processing time and ensuring optimal results.

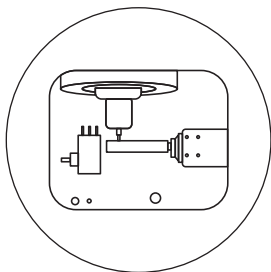

PRECISION MILLING

EXCEPTIONAL DETAIL DISPLAY

Equipped with a custom 0.3mm micro-carving milling cutter and a 0.6mm extended milling cutter, P55D achieves precise milling of facial details, producing restorations that closely resemble natural teeth.

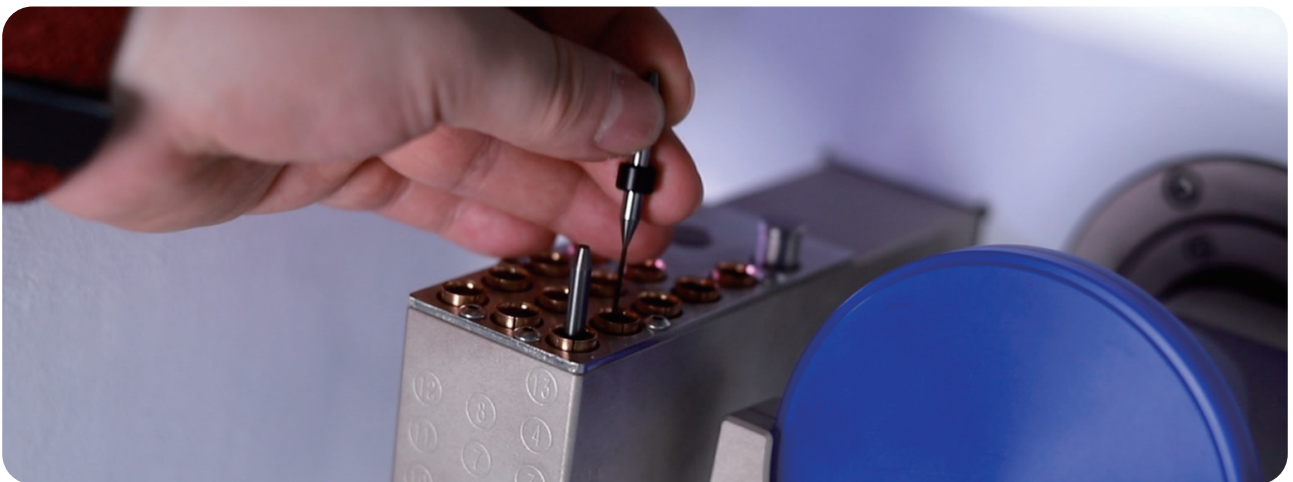



01 INTEGRATED DUSTPROOF DESIGN

Featuring an all-in-one silicone seal for dustproofing, this design effectively prevents dust intrusion into the machine, reducing component wear and maintenance needs, and significantly enhancing longevity.

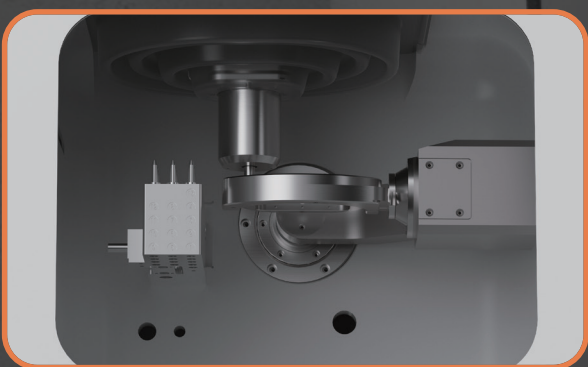

UP3D
P55D

02 LARGE WORKING CHAMBER

A larger milling chamber provides operators with more space and flexibility, enhancing the material handling and removal experience, and effectively increasing work efficiency.



03 IONIZER

P55D features a high-concentration ionizer that neutralizes static in resin debris like PMMA, simplifying cleanup and enhancing efficiency. No need for costly accessories such as air tools, cutting down on both initial and maintenance costs.



04 INNOVATIVE C CLAMP DESIGN

The C clamp design provides expanded space for buccal side milling of restorations, significantly improving material layout and edge utilization to ensure efficient use of materials.



05 PROGRESS-INDICATING LIGHT BAR

The exterior LED bar syncs in real-time with the machine to display processing progress and status, effectively reducing the need for manual checks and enhancing production efficiency.

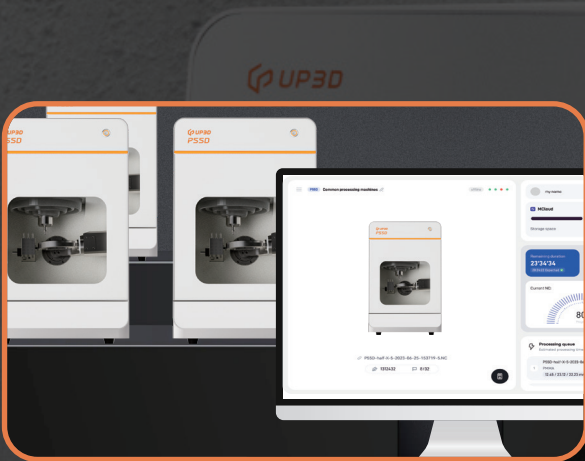

06 CNC MULTI-MACHINE CONTROL

The advanced CNC-3 software controls multiple processing units simultaneously, monitoring and managing several machines in real-time, saving desktop space and reducing computer resource wastage.



07 AUTOMATICALLY RESUME FROM TOOL BREAKPOINT

Wave goodbye to sudden interruptions; our software automatically resumes milling from the last stop, avoiding redundant processing and improving work efficiency by at least 80%.

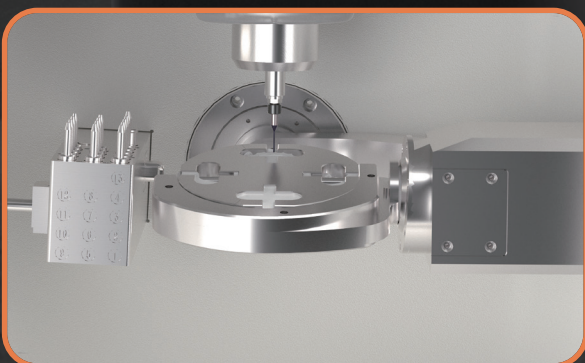

08 ONE-CLICK AUTOMATIC CALIBRATION

One-click smart calibration simplifies operations and automatically optimizes precision, ensuring the accuracy and stability of the equipment, minimizing milling errors, and saving materials to enhance efficiency.



TECHNICAL SPECIFICATIONS



GENERAL	Fields of Application	Dry machining
	Materials	Zirconia,wax,PMMA,PEEK,composite resin,soft milling CoCr sintering metal
	Material Specifications	Discs: height 10-30mm, diameter 98.5mm Blocks up to 40x20x20mm (Max)
	Indications	Crowns, anatomical crowns, screw-retained crowns, inlays, onlays, veneers,
		telescopic crowns, abutments, bite splints, full dentures etc.
BASE SYSTEM	Construction	Machine bed made of solid cast aluminum body
	Number of Axes	5-axis
	Housing	Steel, white high-gloss lacquer finish, main front housing: injection-molded
	Linear Axes (X/Y/Z)	Precision ball screw drive; Travel: 104x60x100mm
	Rotary Axes (A/B)	A-axis: 360°; B-axis: ±33°
	Control Unit	5-axis precision full servo drive system
	Lighting	LED lighting inside the working chamber, with additional status indication
	Power	1.0KW
SPINDLE	General	High-frequency spindle, automatic tool change, no air cooling required
	Speed	Up to 60,000 rpm
	Tool Holding	Diameter Φ 4
	Power	Max. 0.8KW
AUTOMATION	Tool Change	Tool magazine for 13 tools, length measurement and tool breakage monitoring via precision measuring key
CONNECTION REQUIREMENTS	Voltage	100VAC-130VAC, 200VAC-235VAC (selectable), 50~60Hz
	Dust Extraction	Filter level: M; Flow rate: 2500L/min
	Data	Wi-fi, USB, Ethernet port
ENVIRONMENTAL CONDITIONS	Operating Temperature	Between 10°C and 35°C
	Air Moisture	Below 80% (relative), non-condensing
DIMENSIONS & WEIGHTS	Dimensions (W/D/H)	442x560x704mm
	Weight	106KG
SCOPE OF DELIVERY	CAM Software	UPCAM, Millbox

UNLEASH DENTAL CREATIVITY

As a provider in integrated dental CAD/CAM solutions, UP3D provides a complete suite from scanning and design to milling. We're dedicated to fostering creativity and efficiency in dental technology with reliable, high-quality products designed to meet professional needs. Our expert support and training ensure seamless use of our innovative solutions, empowering you to excel in dental craftsmanship.

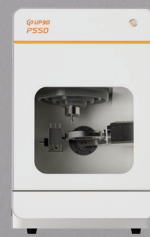
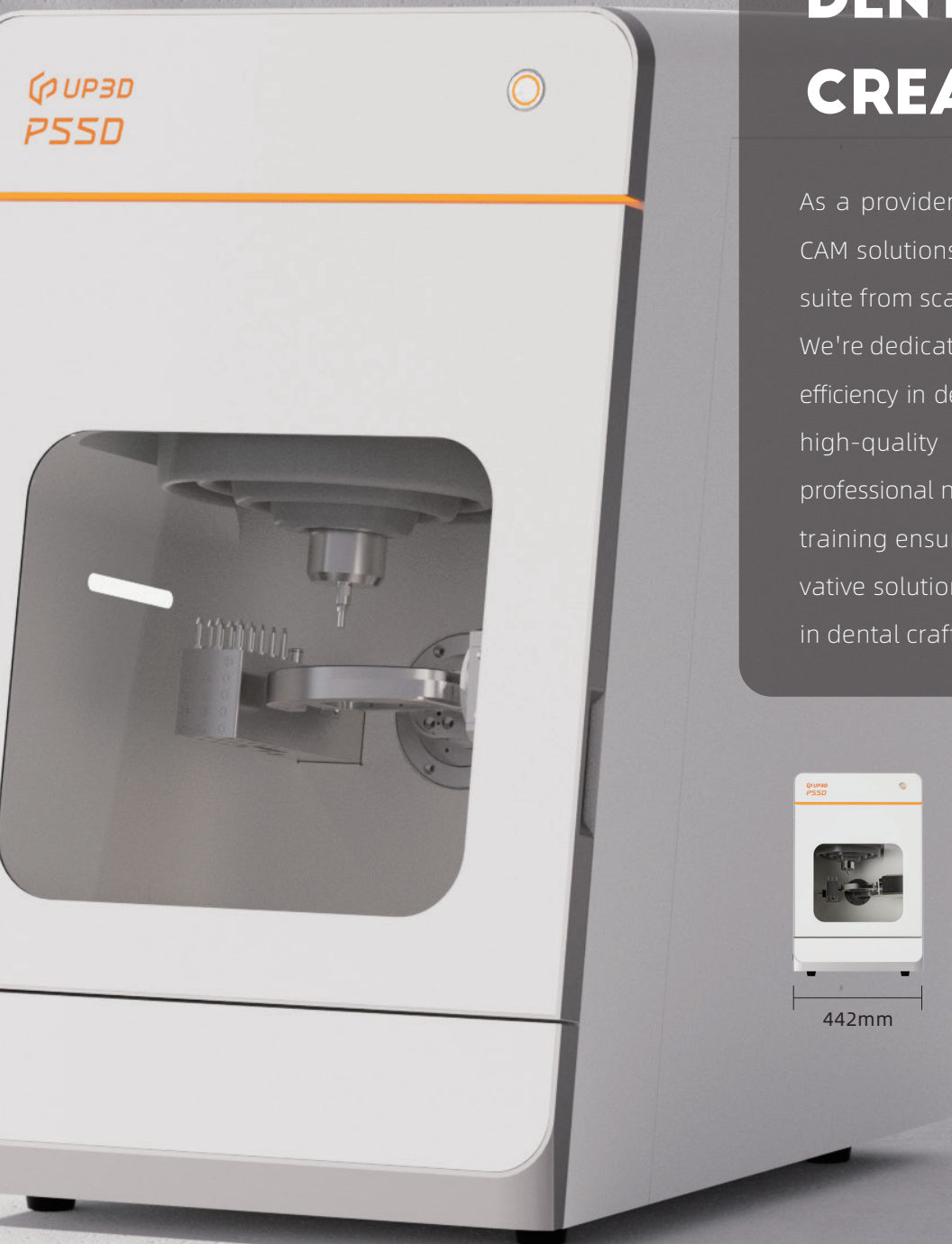

442mm



560mm

704mm



Becoming The Global Leader In An Exceptional Digital Dental Ecosystem



 www.up3ds.com

 info@up3d.cn

 0755-26983202